

Instruction Manual



General Information

This manual provides the necessary information for installation and operation of your flow instrument; for detailed information on any flowmeters or accessories supplied with your instrument please consult the relevant flowmeter product manual. This instrument should only be installed and maintained by persons familiar with local regulations, particularly those for workplace Health and Safety.

For best results, please make yourself familiar with the contents of all relevant product manuals prior to installation and commissioning. If further assistance is required please consult the distributor from whom you purchased your device.



CAUTION

This electronic device is not suitable for use in a potentially explosive atmosphere, which may exist if you are measuring flammable liquids. Please refer to the manufacturer for an alternate product if your installation contains a potentially explosive atmosphere.

DISPOSAL WITHIN THE EUROPEAN UNION - WEEE



- The WEEE Directive requires that this product be recycled when disposed of within the European Union
- The crossed out wheeled bin symbol shown in this manual signifies that this product should not be disposed of in general waste or landfill.
- Please contact the local dealer or national distributor from whom this product was purchased for information on recycling electronic equipment within your region.

Table of Contents

1.	Introduction	4
1.1	<i>Product Overview.....</i>	4
1.2	<i>Specifications.....</i>	5
2.	Operation.....	6
2.1	<i>LCD Display.....</i>	6
2.2	<i>Keypad Function</i>	7
2.3	<i>Operating Functions</i>	7
3.	Mechanical Installation	12
3.1	<i>General Requirements</i>	12
3.2	<i>Electrical Entries</i>	12
3.3	<i>Integral Meter Mounting.....</i>	12
3.4	<i>Wall and Pipe Mounting.....</i>	12
3.5	<i>Panel Mounting</i>	13
4.	Electrical Installation.....	14
4.1	<i>Terminal Identification</i>	14
4.2	<i>Input Connections.....</i>	15
4.3	<i>Output Connections.....</i>	18
5.	Programming Parameters	20
5.1	<i>Enter the Programming Menu.....</i>	20
5.2	<i>PIN Protection.....</i>	20
5.3	<i>Engineering Units.....</i>	20
5.4	<i>Time-base for Rate.....</i>	21
5.5	<i>Decimal Places.....</i>	21
5.6	<i>Input Signal Configuration.....</i>	22
5.7	<i>Calibration Data.....</i>	23
5.8	<i>Digital Output</i>	24
5.9	<i>Advanced Options Menu.....</i>	25
6.	Diagnostics.....	27
6.1	<i>Diagnostic Options.....</i>	27
6.2	<i>Troubleshooting Summary.....</i>	28
6.3	<i>Troubleshooting Steps</i>	29
7.	Programming Flowchart.....	32
8.	Spare Parts.....	36

1. Introduction

1.1 Product Overview

The RT40 Rate Totaliser is designed for computing and displaying volume and volumetric flowrate from a flowmeter with a pulse or frequency output. The instrument will display Flow Rate, Total and Accumulated Total in engineering units as programmed by the user. Simple flow chart programming with English prompts guides you through the configuration steps, greatly reducing the need to refer to the instruction manual. Your instrument is also USB enabled and may be configured on a windows PC using a software utility downloaded from the FLOMEC website. This instruction manual contains some basic information on using the FLOMEC software utility, however please refer to the instruction manual provided with the software for detail instructions on its use.

Environments

The instrument is weatherproof to IP65 standards; a UV resistant glass reinforced nylon housing with stainless steel screws and Nitrile seals allow the instrument to maintain its environmental protection across a wide operating temperature range. The instrument suits harsh indoor and outdoor environments & conforms to the European Directive for Electro Magnetic Compatibility.

Features

Displays of total, accumulated total, instantaneous flowrate, and min/max flowrate are available on the LCD. Flows are computed using 5-point linearisation which allows accuracy improvements for the connected flowmeter. Computed values can be retransmitted to a separate control system using the selectable digital output, with scaled pulse, unscaled pulse or High / Low flow alarms available.

Installation

Specifically engineered to be directly mounted on a variety of flowmeters, wall or surface mounted, pipe or panel mounted. Various mounting kits are available. The instrument can be self-powered or may be powered by an external DC supply.

1.2 Specifications

Physical	Glass reinforced Nylon (PA6) with a Polycarbonate lens, Santoprene gasket, polyester decal. Enclosure provides an IP rating of IP65 Optional powder coated Aluminium enclosure
Temperature	Operating Temperature Range is -30°C ~ +80°C (-22°F ~ +176°F)
Electrical Entries	3 entries - M16 x 1.5
LCD Display:	Large dual line LCD with 6 characters 17mm high on top line, 8 characters 7mm high on bottom line. Backlight available with external DC power.
Units	Total units are selectable for Litres, Cubic Metres, US Gallons, Imperial Gallons, Millilitres (Cubic Centimetres), Quarts, Fluid Ounces, Cubic Feet, Barrels, Kilograms, Pounds, or Custom. Units of mass are configured by setting a units/litre conversion value in the configuration menu.
Input Signals	Two channel pulse/frequency input compatible with standard pulse signals or quadrature signals from most flowmeters.
Compatible Sensors	Reed Switch – 120Hz maximum NPN (hall effect sensor) – 2kHz maximum Variable Reluctance Coils (Turbine Flowmeters) – 2kHz maximum Weigand Sensors (voltage pulse signals) – 2kHz maximum Minimum signal amplitude for Coil signals is 15mV pk-pk
Sensor Power	12V regulated sensor supply is available with external DC power applied.
Battery Power	AA (14505) 3.6V Lithium Thionyl Chloride Battery Expected battery life under ideal conditions is 5 years See section 2.3.11 for more details on battery life
External DC Power	Regulated 12V ~ 30V DC Typical current draw on external power is 100mA across this voltage range
Digital Output	NPN (open collector, sinking) output, 30Vdc / 1A maximum. 100Hz maximum Digital output is configurable as Scaled Pulse, Unscaled Pulse, High Alarm, Low Alarm, or High/Low Alarm.

2. Operation

2.1 LCD Display



Upon entering the programming mode the LCD will conduct a display test where all LCD segments are displayed for 3 seconds



The resettable Total is always shown on the top line of the display.

The accumulated total is shown on the bottom line of the display, indicated by the ACCUM TOTAL flag.



The instantaneous flowrate can be shown on the bottom line of the display by pushing the **Display** key.

All displayed variables are individually selectable for up to 3 decimal places.

The LCD display will update with a frequency of 2Hz when the instrument is operating on battery power. When powered by external DC power the LCD will update with a frequency of 8Hz.

The LCD backlight will automatically illuminate once external DC power is connected to the RT40. This feature can be overridden through the configuration menu to force the backlight to 'OFF'. The backlight can also be set to flash when the flow alarm is triggered by setting the backlight to the 'ALARM' mode.

2.2 Keypad Function

KEY	FUNCTION IN OPERATING MODE	FUNCTION IN PROGRAM MODE
	Press and hold to display firmware revision number and serial number on LCD.	Enter key; selects a program setting, or accepts an entered value
	Press once to display maximum flowrate since last reset. Press again to display minimum flowrate since last reset.	Up key; moves upwards in programming menu, or increments the selected digit when configuring a setting.
	Toggles the bottom display line between accumulated total and instantaneous flowrate	Right key; moves digit selection to the right when configuring a setting
	Press and hold for 3 seconds to reset the total to zero.	Down key; moves downwards in programming menu, or decrements the selected digit when configuring a setting.
	Press and hold both buttons simultaneously for a duration of 5 seconds to enter the programming mode	No Function

2.3 Operating Functions

2.3.1 Resettable Total

The resettable total is displayed on the top line of the LCD. The value that is displayed is the linearised output from the flowmeter.

The default units for the resettable total are Litres, however this can be changed by the user to any of the available engineering units (*see 1.2 Specifications*). When the display units are changed by the user the RT40 will automatically adjust the settings so that no further input is required by the user (k-factors do not need to be changed). If the RT40 is displaying a Total in Litres this will be automatically converted to the new units of measure so that no data is lost.

However, if the new unit selection results in a value which cannot be displayed it will be set to zero. For example, if display units are changed from Litres to Millilitres and the total has a value of 1000L this will be zeroed, as there is not enough display digits for a value of 1,000,000mL.

Pressing the **Reset** key and holding for a period of 3 seconds will reset the total to zero.

2.3.2 Accumulated Total

The accumulated total is displayed on the bottom display line, it can be selected by pressing the **Display** key. The accumulated total is always displayed in the same engineering units as the resettable total.

The accumulated total display can only be reset to zero by accessing the programming menu, *see section 7*, or via USB on a Windows PC. To prevent resetting of the accumulated total the user can use the PIN Protection setting, which can be enabled in the programming menu or via USB on a Windows PC.

2.3.3 Instantaneous Flow Rate Display

The instantaneous flow rate display is displayed on the bottom display line, it can be selected by pressing the **Display** key.

The update frequency of the flow rate display is influenced by two parameters: the update frequency of the display (2Hz on battery power, 8Hz on external DC), and the 'Rate Calculation Pulses' parameter. If the update frequency of the flow rate is too slow, consider reducing the number of pulses for the rate calculation. Conversely if it is required to stabilise an erratic flow rate display, increasing the 'Rate Calculation Pulses' parameter will achieve this.

Other parameters which influence the calculated flow rate value are the 'Filter' setting, and the 'Low Frequency Cut-Off' setting. Increasing the 'Filter' value will smooth out rapid changes in the flow rate to maintain a steady display, however in systems where fast changes in the flowrate must be displayed the 'Filter' parameter should be minimised.

The minimum input frequency requirement for a flow rate display is 0.1Hz, this is also the default setting. With input frequencies below the Low Frequency Cut-Off the RT40 will not be able to display an instantaneous flow rate. Note that Totalisation is not affected by the Low Frequency Cut-off parameter.

2.3.4 Bidirectional Flow Measurement

When using a standard single channel flowmeter with an RT40 users will find that reverse flow in their pipe will produce the same flowmeter pulse signal as occurs during forward flow. This means that reverse flow will be counted by the RT40 as if the flow were still travelling 'forwards'.

To address this issue the RT40 can be used with a flowmeter that has a quadrature output signal – for example an OM series meter with QP option. In this configuration the RT40 can determine the flow direction, allowing measurement of both forwards and reverse flow.

When the RT40 is in Quadrature configuration all the functions of the RT40 will operate as normal, except that reverse flow will now subtract volume from the total and accumulated total display, and a flowrate with a negative sign will be shown on the flowrate display.

When measuring bidirectional flow and using a Scaled Pulse Output, users should note that errors can occur in the transmitted signal when there are periods of reverse flow. This occurs because once a pulse is sent it cannot be 'called back'. During periods of reverse flow, the RT40 will remember the Accumulated Total volume at which the flow reversed. Once the flow has returned to forwards the RT40 will not output any additional pulses until the volume in the Accumulated Total exceeds the volume when the flow reversed.

Using the Unscaled Pulse Output with a quadrature input will simply retransmit the signal from input 1. This means that both forward and reverse flow will output the same pulse signal, making this feature not particularly useful with bidirectional flow.

2.3.5 MAX/MIN Flowrate Display

By pressing the **MAX/MIN** button on the RT40 the user is able to see the minimum, and then the maximum flowrate that has been measured in their system since the last time this feature was reset. By holding down the **Reset** button for 3 seconds while either HI or LO is displayed on the screen will reset both the minimum and maximum values to zero.

This feature is useful when troubleshooting a system where excessively high or excessively low flowrates are suspected, and where it is impractical to be in front of the flowrate display at the exact instant when the fault occurs. An example is where an overnight issue is suspected, the operator can reset their MAX/MIN values before going home for the night. When the operator arrives in the morning, they can see the highest and lowest flows in the system over night.

2.3.6 Display Backlight

The display backlight will be automatically enabled upon connection of an external DC voltage supply in the range of 12-30V; the backlight is not available when operating on battery power. If it is required to reduce power consumption while operating on external DC power the backlight can be overridden by the user.

2.3.7 Unscaled Pulse Output

The Unscaled Pulse Output function is used to retransmit the input signal from the associated flowmeter; it will maintain the same frequency and duty cycle as the input signal. The Unscaled Pulse signal is transmitted as an NPN signal from the digital output terminal.

When setting up a system with two separate displays from the same flowmeter the Unscaled Pulse Output is the best method of transmitting the volume to the secondary instrument. If this is done, the same calibration data should be entered into both displays.

2.3.8 Scaled Pulse Output

The Scaled Pulse Output is used to transmit the totalised volume at a user selectable resolution; this is programmed as a **number of pulses per unit** (e.g. 10 pulses/Litre). This feature is useful whenever it is required to transmit the total volume to a control system such as a PLC or SCADA system.

The scaled pulse output is calculated from the accumulated total, so resetting of the total will not cause any loss of volume on the output signal.

2.3.9 Alarm Output

Flow rate alarms may be programmed for High, Low, or High/Low; the digital output will trigger when the registered flowrate passes the configured set-point(s). For a Low Alarm the output will trigger once the flowrate drops below the set-point, a High Alarm will trigger with a flowrate over the set-point, and a High/Low alarm will trigger if the flowrate is either over the upper set-point or below the lower-set point.

Each set-point is configured with its own hysteresis (dead-band) percentage which allows the user to avoid alarm “chattering” (switching quickly on-off-on-off) with a flowrate hovering around the set-point. The hysteresis setting is entered as a percentage of the set-point value; for example, a 5% dead-band with a 100L/min High Flow Alarm will trigger ON at 100L/min but will not turn OFF until the flow drops to below 95L/min.

2.3.10 Battery Power

The instrument is powered by a Lithium Thionyl Chloride (Li/SOCl₂) AA size battery which is **non-rechargeable**. When operating under average conditions the instrument is expected to have approximately 5 years of battery life; average conditions are considered to be a reed switch input from a FLOMEC flowmeter with no outputs used. High input frequencies (~1kHz and higher) from a turbine flowmeter will reduce battery life by around 20%, and operation of a battery powered scaled pulse output will reduce battery life by approximately 50%. When the NPN transistor is used for an alarm with infrequent operation the reduction of battery life may be negligible.

A low battery is indicated by the battery symbol on the lower right hand side of the LCD; illumination of this indicator shows that the battery should be replaced as soon as possible. Generally the remaining battery life after low battery indication is several days **however this is not guaranteed**. Replacement batteries are available from the instrument manufacturer or they may be purchased independently by the user. For user replacement it is recommended that one of the following batteries be used:

Manufacturer	Model
Tekcell	SB-AA11
SAFT	LS14500
Tadiran	SL360S

Use of a battery which is not a 3.6V Lithium Thionyl Chloride type will void the instrument warranty.

2.3.11 External DC Power

External DC power may be connected to the instrument in the range of 12-30V DC; this will activate the LCD backlight, the sensor supply, and will increase the update frequency of the LCD. When external DC power is provided the instrument will no longer draw any power from the battery – the battery will then only be used as a backup power source. With the battery in backup mode the life is expected to be approximately 8-10years.

2.3.12 Sensor Supply

The instrument is equipped with a 12V regulated sensor supply terminal which is suitable for powering hall-effect sensors in FLOMEC flowmeters. The sensor supply is only available when the instrument is connected to an external 12-30V DC supply.

3. Mechanical Installation

3.1 General Requirements

Installation of this product should only be carried out by suitably qualified/trained personnel with an understanding of local regulations regarding electrical installations.

It is recommended that the instrument is installed in a location where it is shielded from extreme varying weather conditions, and from chances of physical impact. Never install the instrument in an area which will expose it to temperatures outside its specified operating temperature range.

3.2 Electrical Entries

Each instrument is equipped with three electrical entries which are factory sealed to maintain the IP rating of the enclosure. To gain access to an electrical entry remove the threaded plug.

Always use IP rated cable glands when fitting cable to the instrument. Any unused electrical entries must be sealed using an M16 threaded conduit plug with an appropriate IP rating (IP66 or IP67 is recommended)

3.3 Integral Meter Mounting

This instrument may be purchased as a meter mount display which will mount on the top of any OM Series flow meter. For any instruments purchased as field mount, these may be converted to a meter mount instrument by purchasing a new rear enclosure.

For mounting this instrument on an OM Series flowmeter with a process temperature of over 80°C/176°F there is a Cooling Fin Kit (**part no. 1502015**) available from the manufacturer which will allow this; these may be retro-fitted in the field with minimal effort.

3.4 Wall and Pipe Mounting

Mounting of the instrument on a pipe or flat surface (such as a wall) can be accomplished using the Wall Mount Kit (**part no. 1522001**) or Pipe Mount Kit (**part no. 1522002**).

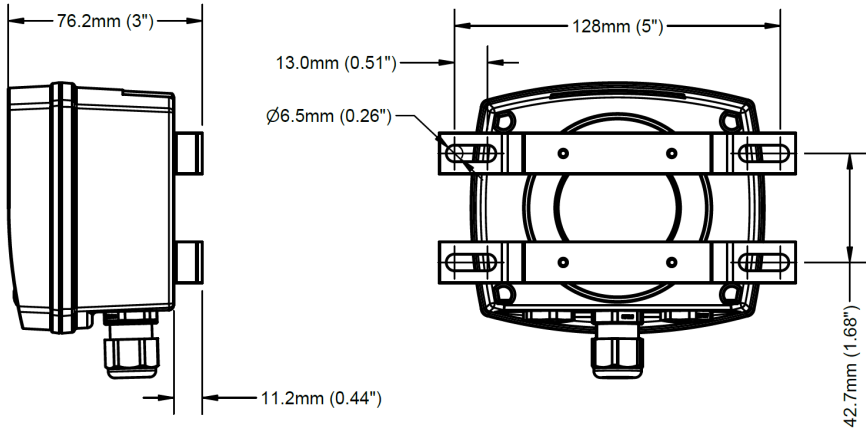

3.5 Panel Mounting

Mounting of the instrument in a panel requires a 95mm x 76mm (3.75" x 3.0") rectangular hole to be cut in the panel – panels thicker than 3.2mm (1/8") should substitute longer screws. The enclosure gasket must be used to maintain weather protection when panel mounted. It is possible to maintain the IP65 rating for the outside of the panel with an accurately cut hole and a flat/smooth panel.

The rear enclosure of the instrument should be mounted behind the panel to protect the electronics module from damage and provide separation from any conductive components inside the panel/cabinet. **However, it should be noted that once panel mounted the rear of the enclosure is no longer protected from water ingress.**

4. Electrical Installation

All wiring connections should be made with good quality shielded instrument cable; wiring between terminals which are inside the instrument enclosure, or between a flowmeter and an integrally mounted instrument may use non-shielded wire. Cable shields or drain wires should be connected to the instrument ground (GND) at the instrument end only – isolate the shield/drain wire at the flowmeter end of the cable.

The terminal connections on the instrument will allow for usage of wiring up to 1.5mm² cross section (16AWG). Wire insulation should be stripped to a length of 7mm and conductors should be fitted to the terminals so that there is minimal exposed conductor. Terminals can be tightened with a 2.5mm flat blade screw driver.

4.1 Terminal Identification

The terminal connections are divided into 4 separate sections by their function, see image below. There is a separate ground (GND) terminal in each section of terminals; as this instrument has a common ground, **all GND terminals are internally connected.**

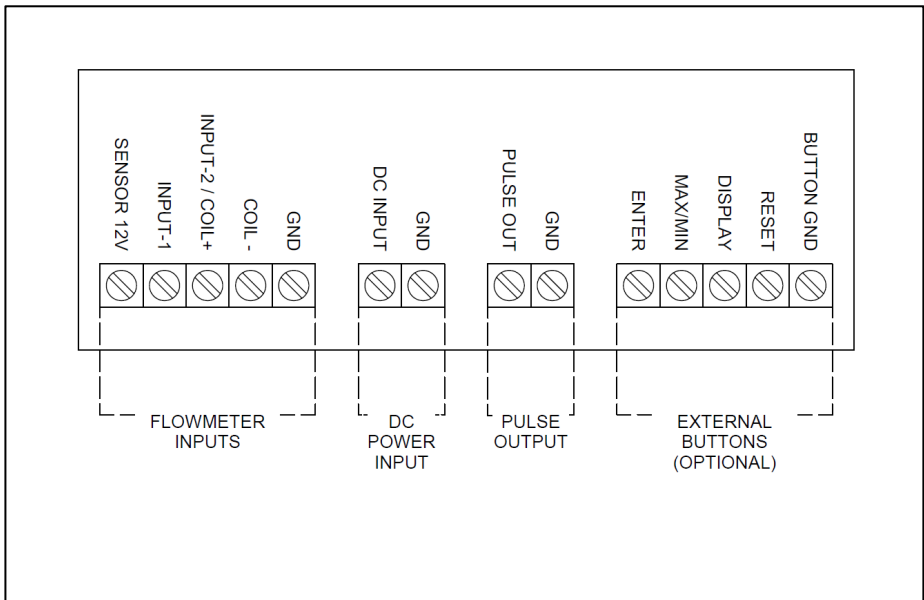

4.2 Input Connections

The input type must be set in the software before the below wiring connections will function.

4.2.1 Reed Switch Input

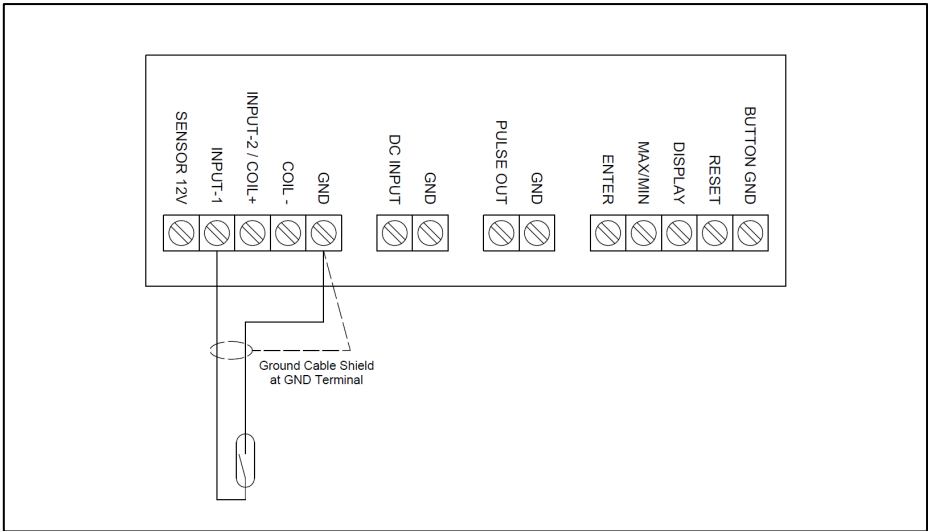

4.2.2 NPN Sensor Input (Hall Effect)

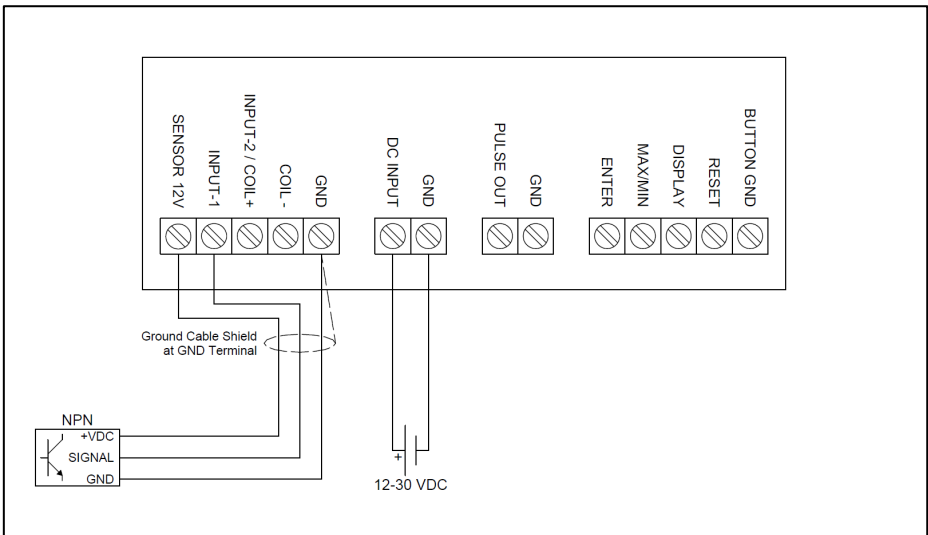

4.2.3 Voltage Pulse Input (Paddle-wheel Meters)

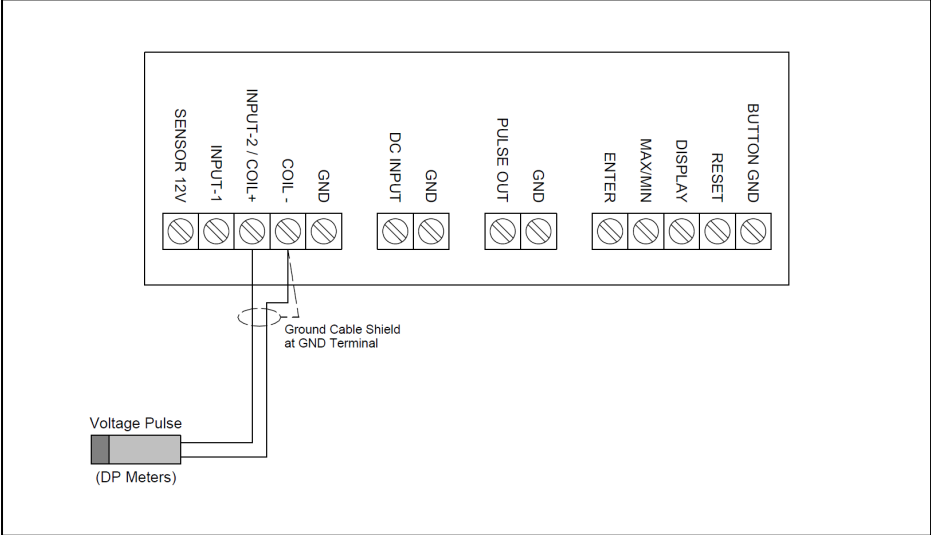

4.2.4 Variable Reluctance Coil Input (Turbine Meters)

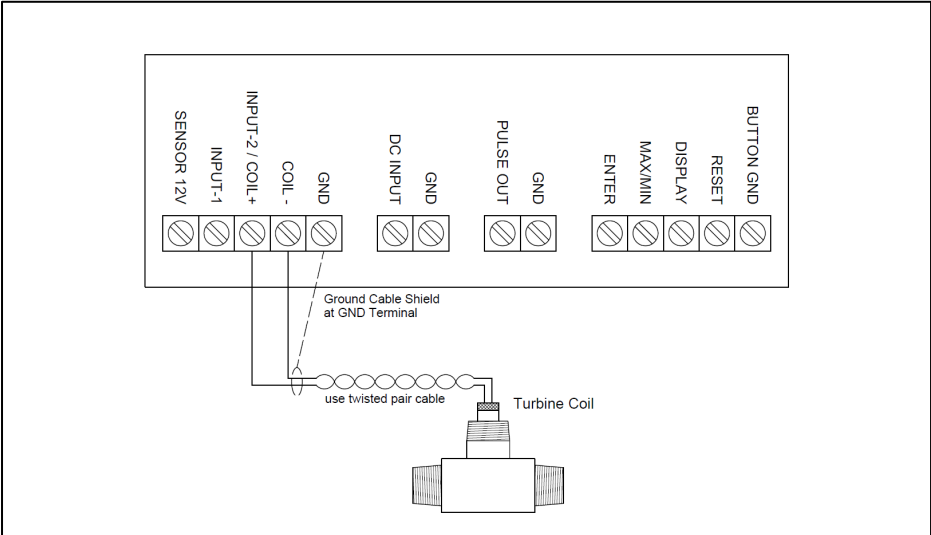

4.2.5 Quadrature Pulse Input (Hall)

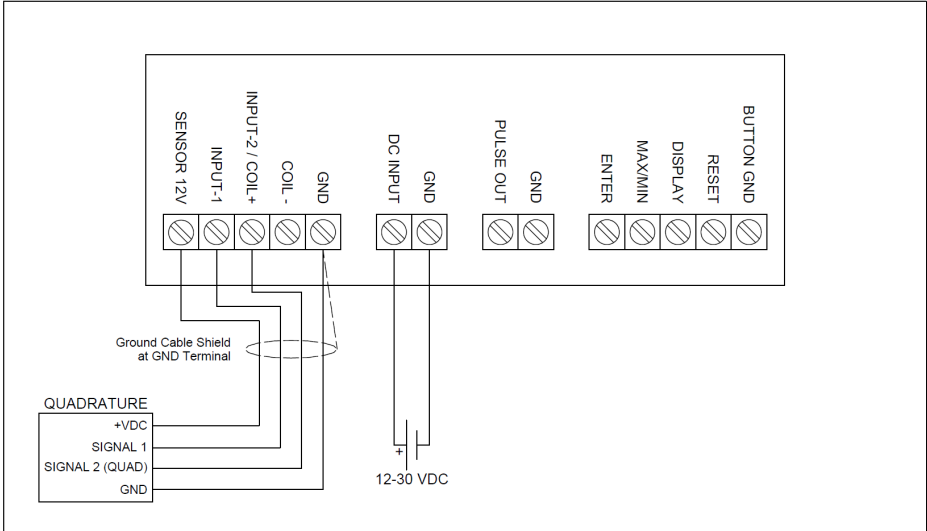

Note: If negative flow is displayed during “forward flow” conditions, swap the wiring connections for signal 1 and signal 2 (Quad).

4.2.6 QS200 / QS100 – 2 Wire Pulse

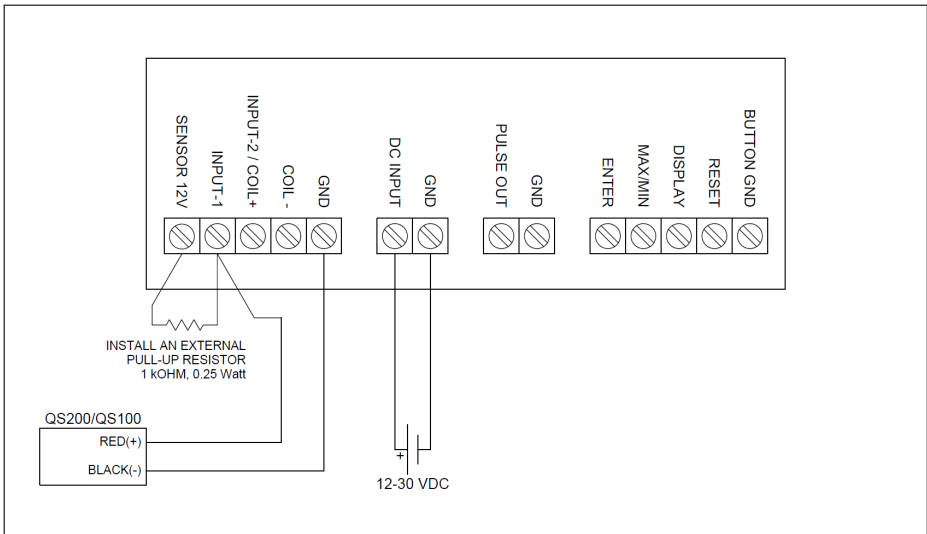

4.3 Output Connections

4.3.1 NPN Pulse or Alarm Output

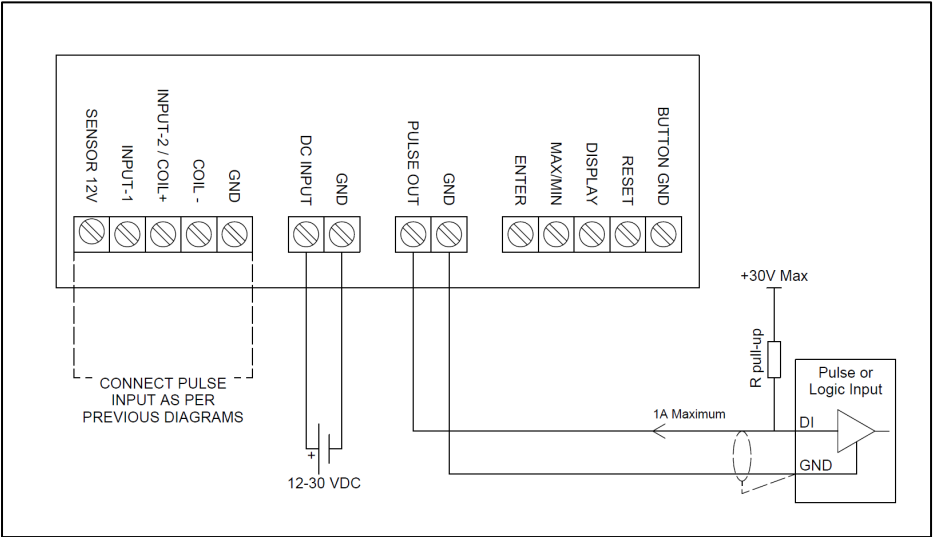

4.3.2 NPN Alarm Output to Relay

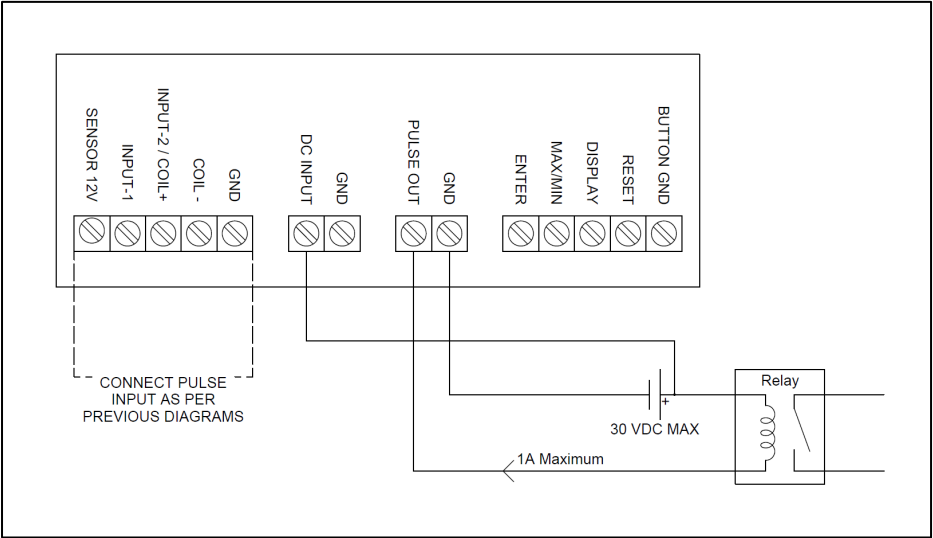

4.3.3 Remote Switches

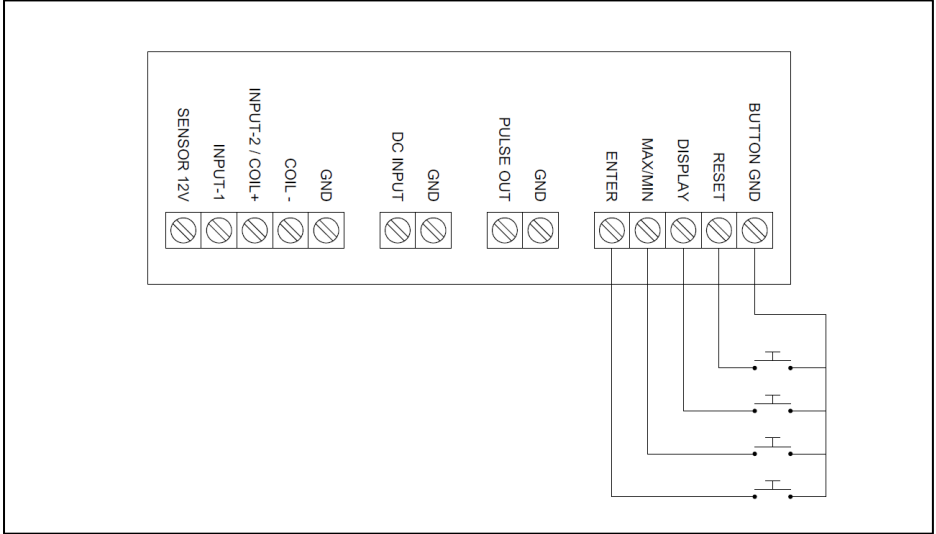

External switches may be connected to the RT40 display to allow remote access to button functions, or to allow use of heavy industrial push buttons in environments where the standard switches may break or wear. Momentary normally open (NO) switches **MUST** always be used.

5. Programming Parameters

5.1 Enter the Programming Menu

To enter the programming menu the user must simultaneously hold the **Max/Min** (up arrow) button and the **Reset** (down arrow) button for a period of 5 seconds. While the user is holding these buttons the LCD screen will display a countdown from 5 to 1. Once this is complete the display will energise all segments to allow inspection of the LCD and identification of any damaged display segments, before finally entering the programming menu. At each level of the programming menu the user presses the **Enter** key to allow adjustment of a setting, the **Up** and **Down** arrow keys to edit the setting, and the **Enter** key again to accept the change.

5.2 PIN Protection

By default, the PIN protection function is off. When entering the programming menu for an RT40 display which does not have a PIN enabled the user will be asked if they want to enter a PIN. Selecting "N" will leave the PIN protection feature OFF and will progress to the next stage of the programming menu.

If the user selects 'Y' they will have enabled the PIN protection feature and may enter a PIN. Any PIN other than 0000 will engage PIN protection of the program settings, or if 0000 is entered the PIN protection feature will return to OFF.

After the PIN protection mode is enabled failure to input the correct PIN will deny the user the ability to change any of the program parameters but will allow read only access to the user so that they may view existing program settings.

Only one PIN may be set at any one time, but this can be changed at any time by entering the programming mode, entering the existing PIN, and then changing the PIN to a new number. A second backup PIN exists in the software which can be used should the user programmed PIN be lost – contact the manufacturer should you require the backup PIN.

5.3 Engineering Units

The engineering units for the instrument may be selected from any in the following table. The factory default units are Litres, however the user may change the display units using the programming menu, or the USB software utility. Once the user has selected an alternative display unit the instrument will recalculate all of the required parameters so that no further data entry is required by the user.

Display Unit	Conversion Factor (units / Litre)	Display
Litres	1	Ltr (right of screen)
US Gallons	0.264172	Ga (right of screen)
Cubic Metres	0.001	m ³ (right of screen)
Pounds	User prompt	lbs (right of screen)
Kilograms	User prompt	kgs (right of screen)
Imperial Gallons	0.219969	Ga (right of screen)
Millilitres (cubic centimetres)	1000	cc (main display)
Quarts	1.05669	qt (main display)
Fluid Ounces	33.814	FL.O (main display)
Cubic Feet	0.0353147	Cu.Ft (main display)
Barrels	0.0062898	bbl (main display)
Custom	User prompt	CUST (main display)

For any units that are not available in the above table the user may choose to select ‘Custom’ units. Once this has been selected the user will be prompted to enter a conversion factor. For example, to configure the instrument for decalitres select ‘Custom’ units and enter a conversion factor of 0.1 decalitres per litre.

The user may also select units of mass, either kilograms or pounds. Please note that this will always be a less accurate measurement than if you are displaying a volume unit, as we are assuming a fixed density for the measured liquid. This would only be accurate if you have a very stable temperature. Once a unit of mass is selected by the user they will be prompted to enter the number of mass units per Litre; either kilograms/litre or pounds/litre.

For kilograms this is equivalent to the specific gravity of the liquid.

5.4 Time-base for Rate

The time-base for the Rate display may be selected from any of the following; units/second, units/minute, units/hour, units/day. The Rate time-base setting will determine the units used in programming the setpoints for the high alarm or low alarm.

5.5 Decimal Places

Decimal places are separately adjustable for Total, Accumulated Total, and Rate from zero to three decimal places. The decimal places setting for Rate will set the available decimal places for the high alarm or low alarm. The decimal place settings for Total and Accumulated Total do not affect any other settings.

5.6 Input Signal Configuration

The input signal can be configured according to the number of input channels; single channel, or quadrature. The default input type is “SINGLE” and is the correct input type for most flowmeters. If the RT40 is to be used with a flowmeter with quadrature output – a 2 channel signal which typically has 4-wires – “QUAD” should be selected, which will allow the RT40 to detect flow direction and calculate both forward and reverse flow.

After selecting the input type, the sensor type can be selected from; Hall effect sensor, Reed switch, or Coil. The following table should be referenced when selecting the correct software setting for your flowmeter. ***Instruments factory mounted to a flowmeter will have this parameter factory set and do not require user adjustment.***

<i>Flowmeter Type</i>	<i>Situation</i>	<i>Input Type</i>	<i>Sensor Type</i>
Oval Gear meter	Standard oval meter with locally mounted RT40	SINGLE	REED
Oval Gear meter	Electrically noisy environment, high temperatures or large temperature swings	SINGLE	HALL
Oval Gear meter	Measuring bidirectional flow	QUAD	HALL
Turbine meter	Standard turbine flow meter	SINGLE	COIL
Insertion paddlewheel meter	Standard paddlewheel meter with voltage pulse sensor	SINGLE	COIL
QS200 / QS100 ultrasonic meter	2-wire pulse signal from QS200 or QS100 water meter	SINGLE	HALL

5.7 Calibration Data

The calibration data menu allows the user to enter up to 5 points of calibration data for their flow meter; if the RT40 was purchased integrally mounted to a flow meter then the calibration data will be factory set.

Upon entering the calibration data menu the user is able to enter up to 5 points of calibration, with each point of calibration requiring a frequency value and a K-factor. Frequency values are to be entered in Hertz (pulses/second) and can be entered with up to 4 whole numbers and 1 decimal place. K-factor values are to be entered in Pulses/Litre with up to 6 whole numbers and 4 decimal places.

It is very important to note that K-factors are always entered in units of Litres regardless of the units chosen for the display.

If a single point of calibration is to be entered, the frequency value is not important and any non-zero value can be entered here. After entering a non-zero value for frequency the K-factor for the flowmeter may be entered. ***Please note, if there are no non-zero frequency values entered the RT40 will operate as if the K-factor has been set to 1 Pulses/Litre.***

When entering multiple points of calibration the user must calculate the frequency for each calibration point, which can be done as follows:

$$\text{Flowrate} \left(\frac{\text{Litres}}{\text{minute}} \right) \times \text{K.Factor} \left(\frac{\text{Pulses}}{\text{Litre}} \right) \div 60 = \text{Frequency(Hz)}$$

Example: for a calibration point at 50 L/min with a K-factor of 107 Pulses/Litre the user would enter a frequency value of 89.2Hz and a K-factor of 107 Pulses/Litre

Calibration points may be entered in any order, it is not necessary to enter them in ascending frequency order. However, if any point is entered with a frequency value of zero then all remaining calibration points will be disabled. If data is entered for the first 3 points of calibration, and point 4 is entered as zero Hz then points 4 and 5 will be disabled and the RT40 will operate with 3 points of calibration.

For users with a QS200 or QS100 ultrasonic water meter; the calibration data to enter should be a frequency of 1Hz, and a K-factor selected from the "Reference Pulses/Litre" column of the K-factor table in the QS200 or QS100 instruction manual. Please note that the correct Pulses/Litre number must be selected based on your pipe size and your pipe schedule.

5.8 Digital Output

The digital output function is configurable for either a pulse output according to totalised flow, or an alarm output according to flowrate. The pulse output can be configured for an unscaled pulse or a scaled pulse, and the alarm can be configured for notification of high flowrates, low flowrates, or a combination of both.

5.8.1 Un-Scaled Pulse

The unscaled pulse output, also commonly referred to as a ‘repeater pulse’, is enabled by selecting ‘UNSCALED’ in the digital output configuration menu.

5.8.2 Scaled Pulse

The scaled pulse output is enabled by selecting ‘SCALED’ in the digital output menu. Configuration of this output is accomplished by entering the number of pulses per unit; e.g. 10 pulses/Litre, 1 Pulse/Gallon, etc.

The user may configure this setting in the range of 999.99 – 0.01 pulses per unit, however it is not possible to output a higher resolution than that of the input signal. For example, if your flowmeter output resolution is 100 pulses per Litre, then the scaled pulse output must be configured for less than 100 pulses per Litre.

The frequency of the Scaled Pulse Output signal automatically adjusts according to the input frequency and the scale factor, up to a maximum limit of 100Hz. If it is necessary for the scaled pulse output to operate at greater than 100Hz the instrument will output the signal at the maximum of 100Hz, and all excess pulses will be stored in memory until such a time that flow has stopped and the instrument can output the stored pulses – it is not recommended that systems be designed to operate in this way under normal conditions.

The output frequency can be calculated as follows:

$$\text{Frequency} = \frac{\text{Maximum Flowrate (units/minute)} \times \text{Scaling Factor (pulses/unit)}}{60}$$

If the system design does not allow significant periods of zero-flow where the instrument can reduce the stored pulse count to zero it is advisable to decrease the number of pulses per unit, in order to keep the output below 100Hz.

The pulse width of the Scaled Pulse output is fixed at 300ms for output frequencies below 1.67Hz, however once above 1.67Hz the instrument adjusts the pulse width according to the frequency to give a 50:50 duty cycle up to the maximum output frequency of 100Hz.

5.8.3 Flow Alarm

The Alarm output is enabled by selecting 'ALARM' from the digital output menu. The alarm output may be configured as a 'High Alarm' which will trigger in the event the flow rate exceeds the alarm set-point, a 'Low Alarm' which will trigger in the event the flow rate drops below the set-point, or a 'High/Low Alarm' which is a combination of the two.

Configuration of the Alarm involves selecting the type of alarm, entering the alarm set-point (*specified in Rate units, e.g. L/min*), and entering the hysteresis value.

The Alarm hysteresis is an adjustable buffer zone around the set point which allows the user to overcome alarm chattering when the flowrate is fluctuating around the set-point. If you find that your flow alarm is repeatedly switching on/off it is possible you need to set a higher value for hysteresis.

The hysteresis setting is entered as a percentage of the set-point value. For example, a 100L/min High Flow Alarm with 5% hysteresis will trigger ON at 100L/min but will not turn OFF until the flow drops to below 95L/min.

Notification that a Flow Alarm has been triggered is typically done through an external light or siren wired to the output terminals of the display. Alternatively, the output from the display can be connected to an external control system such as a PLC. In addition, the backlight may be used in ALARM mode, which allows the display backlight to flash in the event of an alarm.

5.9 Advanced Options Menu

5.9.1 Resetting Accumulated Total

Resetting the accumulated total can only be done at this level of the Advanced Menu. If the display is PIN protected it will not be possible to reset the accumulated total. Once the accumulated total is reset it is not possible to recover the value which was in the accumulated total – it is advisable to record the accumulated total value before resetting.

5.9.2 Low Frequency Cut-Off

The low frequency cut-off parameter is used to adjust the minimum frequency required for the rate display. This setting is useful to avoid spikes in the rate display from "apparent flow" which could be caused by movement of liquid in the pipes of a mobile installation (on a truck etc.), pulsations from a dead-headed pump, etc.

The default value for the low frequency cut-off is 0.1Hz, and the parameter is adjustable from 0.1Hz up to 9.9Hz. It is not possible to enable a rate display for input frequencies below 0.1Hz.

5.9.3 Rate Calculation Pulses

The purpose of the 'Rate Calculation Pulses' parameter is to determine the number of input pulses which are used in calculation of the flow rate; the more pulses which are used the more accurately the Rate Display will represent the **average** flow rate of the system. The parameter is adjustable from 1 to 99 pulses per calculation.

For systems using pumps with a non-uniform rate of delivery (*piston pumps or similar*) it is important to have a high value for this parameter as it will produce a stable rate display which is representative of the average flow through the pipe.

For systems with a steady and uniform flow through the pipe, lower values can be used for this parameter in order to achieve a more responsive rate display. However, it should be kept in mind that for any battery powered applications, using a value lower than the default will decrease battery life.

5.9.4 Flow Rate Filter

The Flow Rate Filter is used to smooth out fluctuating flow input signals in order to provide a stable flow rate display. Most input signals are reasonably stable and need only the default setting, however for systems with large flow fluctuations the Filter setting may need to be increased.

If the user requires quick visual indication of changes to a system's flowrate, this can be accomplished by entering a lower number. To remove all filtering from the flow rate calculation this parameter can be set to zero.

5.9.5 Backlight Override

The backlight is automatically enabled whenever external DC power is connected to the instrument; this feature may be overridden in this level of the program. The backlight override may be set to 'ON' (normal function), 'OFF' (always off), ALARM (triggered with an alarm). Note that the ALARM backlight mode still requires external DC power.

6. Diagnostics

6.1 Diagnostic Options

6.1.1 Serial Number

The serial number screen allows the user to see the serial number for their product. This number will also be shown on the physical label on the outside of the display enclosure. This number may be needed if you contact FLOMEC for technical assistance.

6.1.2 Input Frequency

The input frequency screen will display the current input frequency in Hertz on the LCD screen. This number is unaffected by any settings configured into the display by the user, so is therefore independent of any mistakes made in setting up the product. The input frequency display can be useful when troubleshooting.

6.1.3 Voltage

The voltage display indicates to the user if the display is running on battery power, or if there is an externally connected DC voltage supply of sufficient voltage. This can be useful in situations where the digital output or backlight are not functioning, to determine if sufficient voltage is available at the external power terminals.

6.1.4 Test Output

The “test output” function allows the user to force an output pulse signal of 10Hz without the requirement for any flow in their system. This function is very useful when commissioning an external instrument such as a fuel management system, PLC, or datalogger. By enabling the “test output” function the user will be able to test electrical connections and FMS/PLC settings without the need to run pumps or open valves.

This function is also very useful when troubleshooting a system where a PLC or fuel management system is not receiving a pulse signal from the flowmeter display. By enabling the “test output” function the user can isolate the issue to either the input side or the output side of the RT40.

6.2 Troubleshooting Summary

Symptom	Probable Cause	Corrective Action
INACCURATE READINGS	<ol style="list-style-type: none"> 1. Incorrectly entered calibration data 2. Electrical interference 3. Mechanical or electrical fault with flowmeter 4. Flowmeter requires recalibration 	<p>See 6.3.2 below</p> <p>Contact the manufacturer if a product fault is identified</p>
TOTAL NOT COUNTING WITH FLOW IN PIPE	<ol style="list-style-type: none"> 1. Incorrect configuration 2. Incorrect wiring 3. Product fault 	<p>See 6.3.1 below</p> <p>Contact the manufacturer if a product fault is identified</p>
ZERO FLOWRATE DISPLAY WITH FLOW IN PIPE	<ol style="list-style-type: none"> 1. Incorrect configuration 2. Product fault 	<p>See 6.3.2 below</p> <p>Contact the manufacturer if a product fault is identified</p>
UNEXPECTED CHARACTERS ON LCD SCREEN	Faulty LCD segment	Enter programming mode to test display segments. Confirm that all LCD segments are illuminating as per image on page 6 of this instruction manual. If a segment(s) is not illuminating contact the manufacturer
NO PULSE OUTPUT RECEIVED	<ol style="list-style-type: none"> 1. Incorrect configuration 2. Incorrect wiring 3. Faulty receiving instrument (PLC, FMS, etc.) 4. Product fault 	<p>See 6.3.5 below</p> <p>Contact the manufacturer if a product fault is identified</p>

6.3 Troubleshooting Steps

6.3.1 Total Not Counting

If the total display on the RT40 is not counting it will be necessary to determine if the cause of the fault is a flowmeter failure, failure of the RT40 itself, or incorrect setup of the RT40.

Following the below steps will allow the user to identify the likely fault.

1. Confirm the correct input type has been configured (**see section 5.6**)
2. Once the correct input type is set; use the Input Frequency diagnostics menu (**section 6.1.2**) to identify if an input signal is being detected by the RT40.
3. If an input signal is being detected, but the total display is not counting, please check your K-factor setting has not been programmed as zero.
4. If an input signal is not being detected; disconnect the wires connecting your flowmeter sensor to the RT40. With the input type set to REED, using a short piece of wire or a paperclip, momentarily connect the "Input1" terminal to the "GND" terminal to simulate the closing of a reed switch sensor. If the input frequency reading in the diagnostics menu shows a reading, the fault is with the flowmeter or the wiring from the flowmeter to the RT40.
5. If step 4 does not cause a reading on the Input Frequency display, there may be an electrical fault with the RT40, please contact FLOMEC technical support.

6.3.2 Zero Flowrate

If the flowrate display on the RT40 is reading zero, but the total volume is counting there may be an issue with configuration settings. If the flowrate and total readings are both non-functional, please **see section 6.3.1** above. To troubleshoot this issue please follow the below steps.

1. Ensure the units of measure are appropriate for the amount of flow in your pipe. If you have cubic metres set on your RT40 and are measuring flow in a ¾" pipe this may be an issue (**see section 5.3**)
2. Ensure the flowrate timebase is not set too large (i.e. /day) creating a value of flowrate too small to be displayed on the screen (**see section 5.4**)
3. Set the flowrate decimals to 3 to ensure sufficient resolution to pick up low flow rates (**see section 5.5**)
4. Set the low frequency cutoff setting to the default value of 0.1Hz (**see section 5.9.2**)
5. Set the rate calculation pulses setting to the default value of 4 (**see section 5.9.3**)
6. Set the filter setting to the default value of 25 (**see section 5.9.4**)
7. If the issue persists you may have a fault in your RT40, please contact FLOMEC technical support.

6.3.3 Inaccurate Readings

If the RT40 display is showing inaccurate readings of flowrate or total volume the possible causes are; incorrect configuration settings in the RT40, electrical noise, or a faulty flow meter. Please follow the below steps to troubleshoot this issue.

1. Obtain the calibration certificate for your flowmeter, if you no longer have the calibration certificate for your flowmeter you will need to contact FLOMEC technical support or the FLOMEC distributor from whom you bought your meter. **Please note: you will need to have the serial number for your flowmeter, which is located on the flowmeter itself – the serial number for your RT40 display is not the serial number you need.**
2. Once you have the calibration certificate for your flowmeter please confirm the K-factor values have been correctly entered into the Calibration Data for the RT40 (**see section 5.7**). **Please note that K-factor values must be entered in Litres even if you have chosen to display readings in another unit of measure.**
3. If calibration data is correct; while your flow meter is operating (there is flow) go to the Input Frequency diagnostics menu (**see section 6.1.2**). If the input frequency reading is erratic or unsteady, it is likely you have an issue with electrical noise interfering with the pulse signal from the flowmeter. This issue will typically present as flow readings being too-high on your RT40. Electrical noise issues can typically be fixed with shielded cables, properly grounded at the RT40 and isolated at the flowmeter. Also re-run cables away from solenoids and electric motors.
4. If all of the above steps do not uncover a cause of the inaccurate readings, it is likely your flowmeter is faulty, or in need of recalibration. Please refer to the instruction manual for your flowmeter, or refer to the flowmeter manufacturer for technical support.

6.3.4 Backlight not Illuminating

If the backlight does not illuminate on your RT40, follow the below steps:

1. Please note that the backlight will only function if external DC power is connected. It will not function on battery power.
2. Check the backlight is not configured to “OFF” (**see section 5.9.5**)
3. Check there is sufficient external voltage available to power the backlight, using the Voltage diagnostics menu (**see section 6.1.3**)
4. If the backlight is configured to be ON, and the diagnostics menu shows sufficient external voltage it is possible your backlight is faulty. Please contact FLOMEC technical support.

6.3.5 No Pulse Received at PLC or FMS

If your RT40 is correctly displaying a flowrate and total but you are not receiving a pulse signal at your PLC, fuel management system, or any other device with a frequency input, this may be due to a fault at either the RT40, the external device, or incorrect/broken wiring. To troubleshoot this fault please follow the below steps.

1. If your RT40 is not counting volume on the Total screen, and/or not displaying a flowrate reading, please first **refer to sections 6.3.1 and 6.3.2**
2. Enable the “test output” function in the diagnostics menu (**see section 6.1.4**). If enabling this function causes the PLC/FMS to begin receiving pulses, then there is possibly a fault with the RT40, or it is possible the input frequency of the PLC is limited. Make sure you are using a Scaled Pulse Output and try reducing the resolution of the output pulse until the PLC is able to read the signal (**see section 5.8.2**)

If the RT40 is correctly displaying a total and flowrate, and the “test output” function does not cause the PLC/FMS to begin receiving pulses, then we must validate the output of the RT40 with another device.

3. If a second RT40 is available; disconnect the wiring from the RT40 to the PLC or FMS. Then connect the output terminals of your RT40 to the input terminals of the diagnostic RT40 using short lengths of wire. With the diagnostic RT40 configured with a HALL input signal, go to the Input Frequency diagnostics menu on the 2nd RT40. If the 2nd RT40 is displaying a reading of 10Hz then your original RT40 is functioning correctly, and your fault is with the PLC/FMS or the wiring.
4. If a 2nd RT40 is not available, a digital multimeter with a frequency(Hz) setting is a suitable alternative. If after conducting these measurements directly on the output terminals of the original RT40 you cannot measure a frequency of 10Hz, then there is a fault with the RT40. Please contact FLOMEC technical support.

7. Programming Flowchart

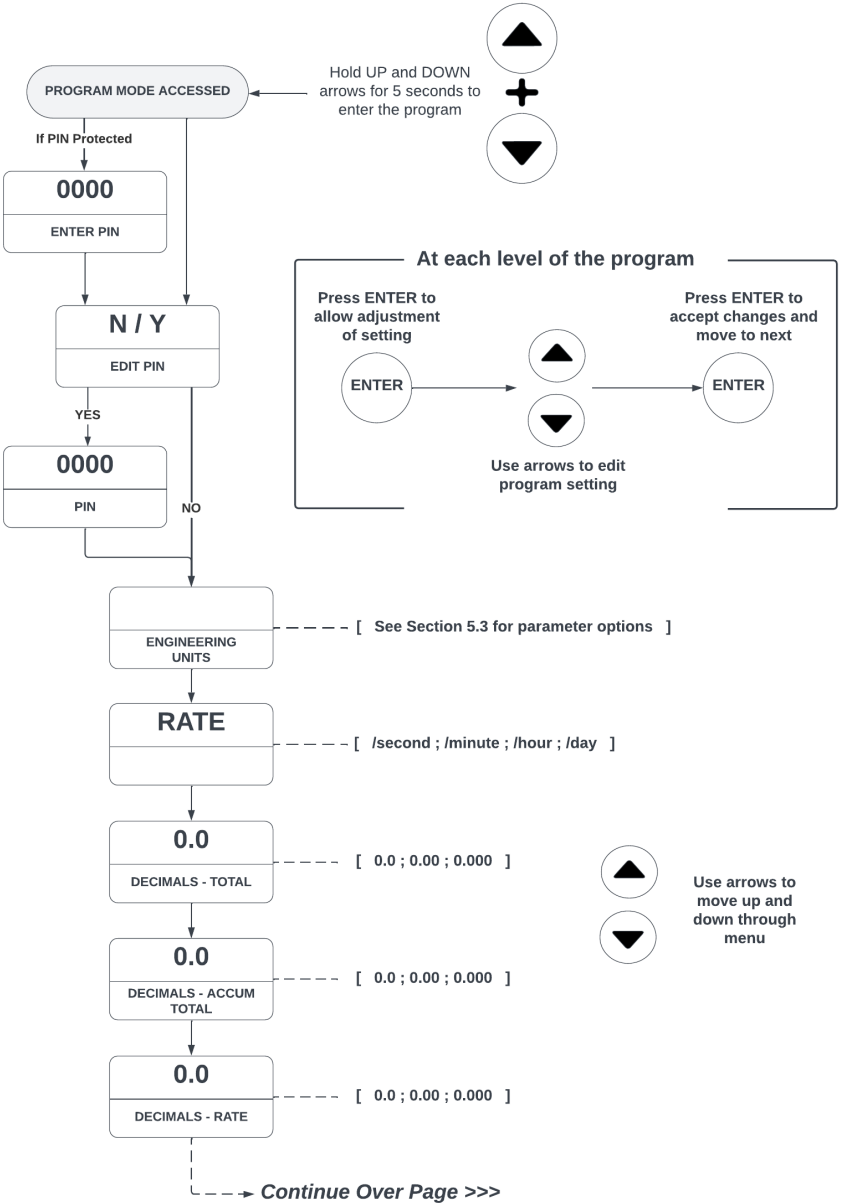

>>> From Previous Page

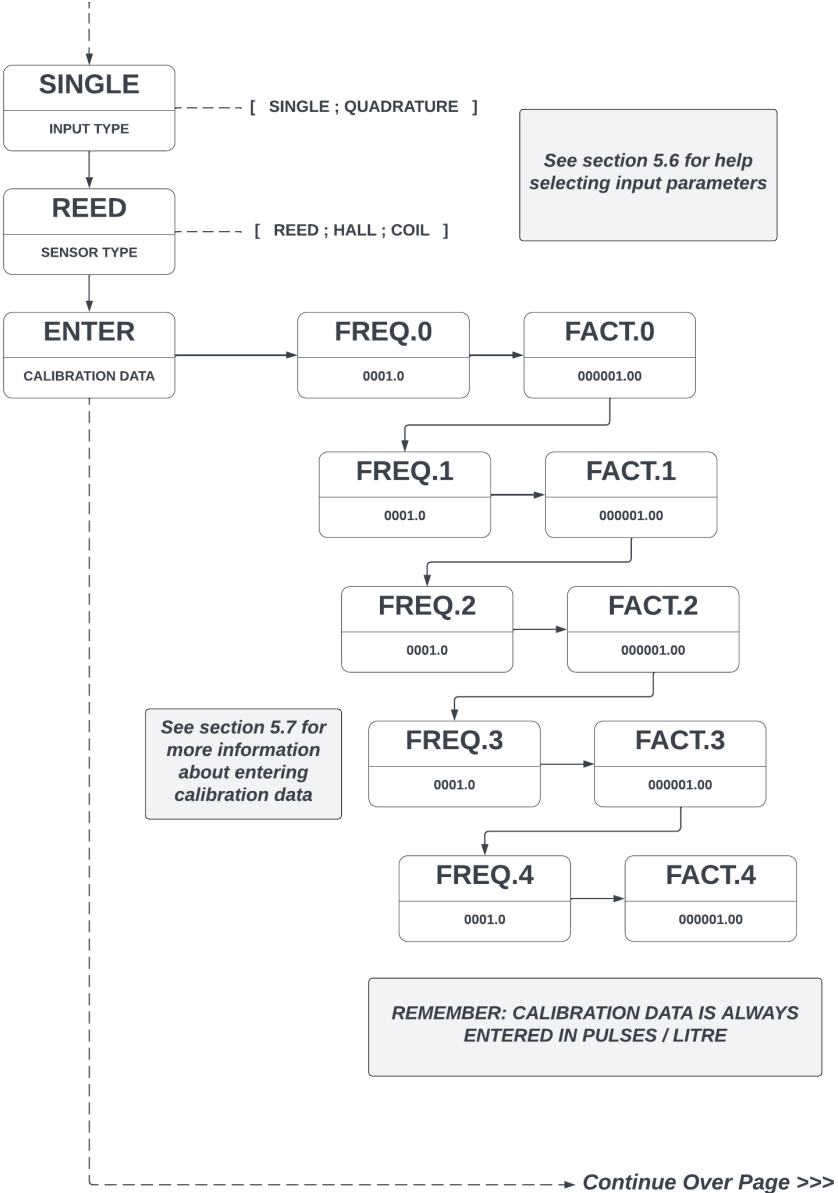

>>> From Previous Page

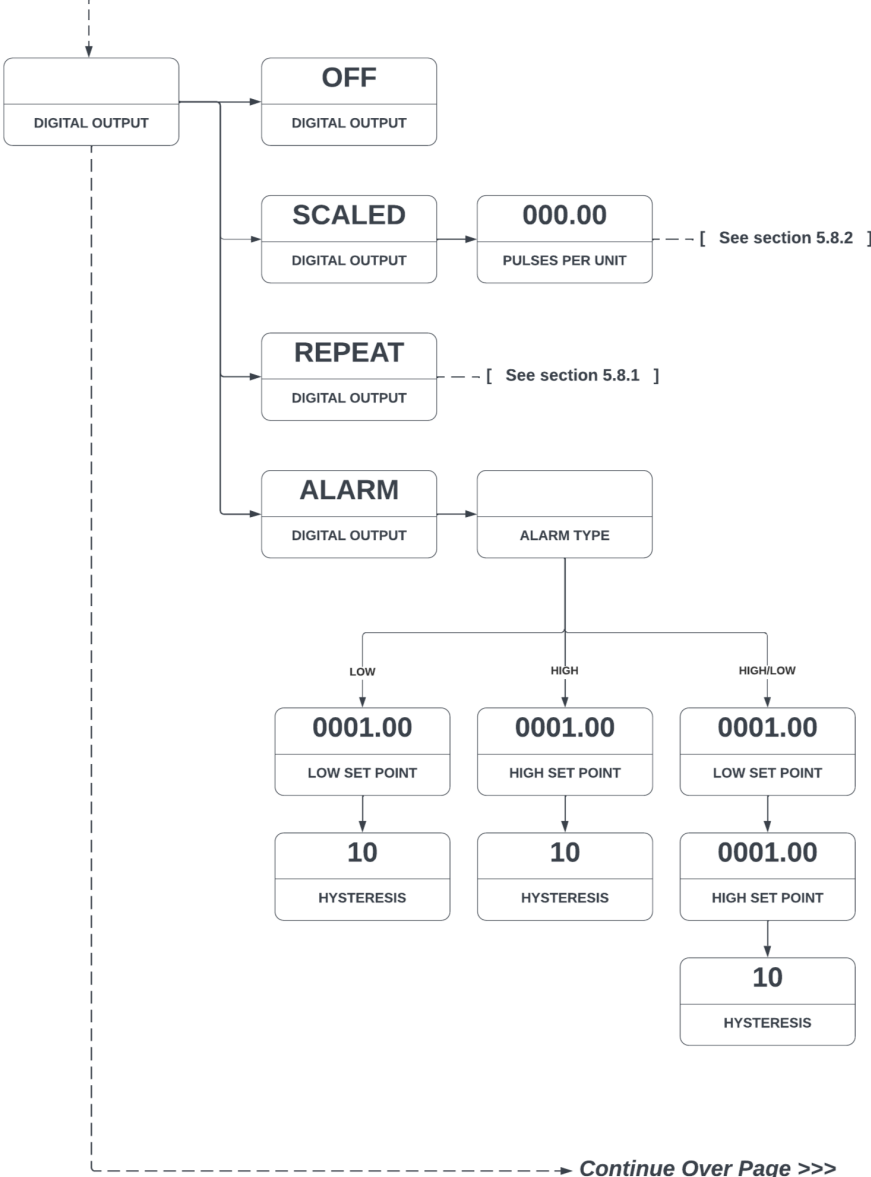

>>> From Previous Page

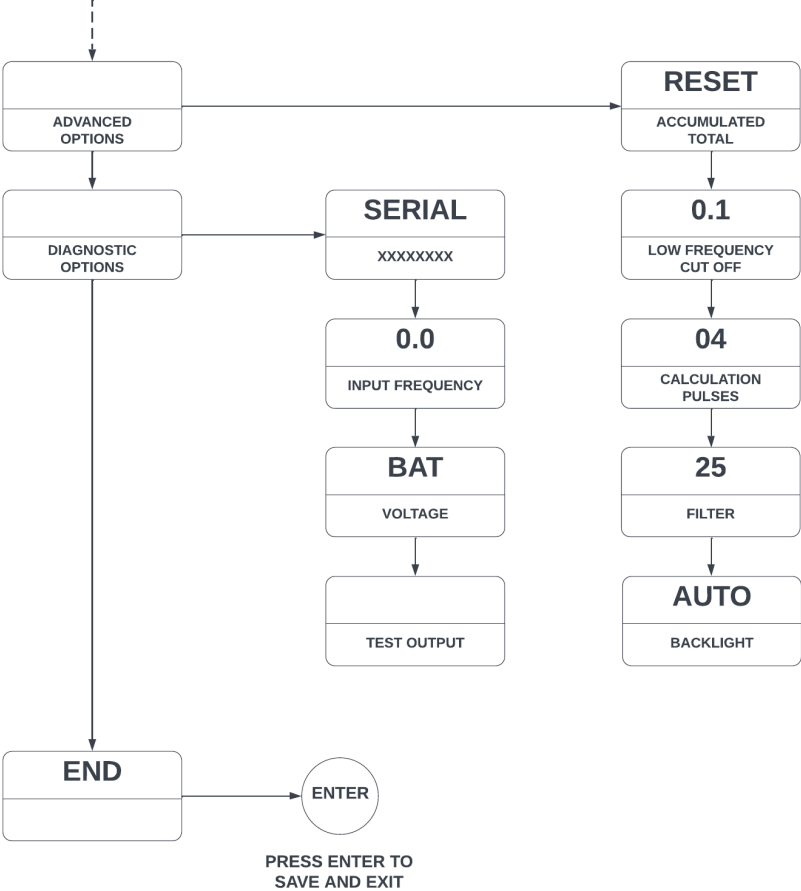

8. Spare Parts

Spare parts for your instrument are available from the local dealer or national distributor from whom you purchased the instrument; see spare parts list below to determine which part numbers you require.

Description:	Includes:	Part No:
Front Housing Kit (GRN)	Front housing (glass reinforced nylon), screen cover, FLOMEC decal, screws, and gasket	1502070
Front Housing Kit (Aluminium)	Front housing (aluminium), screen cover, FLOMEC decal, screws, and gasket	1502037
Meter Mount Rear Housing Kit (GRN)	Rear housing for meter mounted instrument (glass reinforced nylon); Includes the required fasteners and seals for meter mounting	1502069
Meter Mount Rear Housing Kit (Aluminium)	Rear housing for meter mounted instrument (aluminium); Includes the required fasteners and seals for meter mounting	1502034
Field Mount Rear Housing Kit (GRN)	Rear housing for field mounted instrument (glass reinforced nylon)	1502068
Field Mount Rear Housing Kit (Aluminium)	Rear housing for field mounted instrument (aluminium)	1502035
Screen protector kit	Polycarbonate screen cover, and screws	1506018
Housing Gasket	BS046 Buna-N (Nitrile) O-Ring	1304024
Meter Mount Seal	BS039 Buna-N (Nitrile) O-Ring	BS039B
Decal (facia)	Self-adhesive decal (facia) with FLOMEC logo	1315187
Replacement Battery	3.6V AA Lithium Thionyl Chloride Battery	1312125
<i>Alternative Replacement Battery for Safe Area Units Only</i>		Tekcell SB-AA11 Tadiran TL5903/S
Wall Mount Kit	2x wall mount brackets, 4 mounting screws	1522001
Pipe Mount Kit	Wall mount kit plus pipe clamps	1522002

Notes:

Notes:

A large, empty rectangular box with a thin black border, intended for handwritten notes.

Notes:



Service & Warranty

For Technical Assistance, warranty replacement or repair in North or South America contact your Flomec Distributor or contact

Great Plains Industries, Inc.
5252 East 36th St. North Wichita,
KS, USA 67220-3205

888-996-3837

greatplainsindustries.com

For Technical Assistance, warranty replacement or repair outside North America contact your Flomec Distributor or contact

GPI Australia
(Trimec Industries Pty. Ltd.)
12/7-11 Parraweena Road
Caringbah NSW 2229
Australia

+61 02 9540 4433

www.flomec.com.au